

BUK100

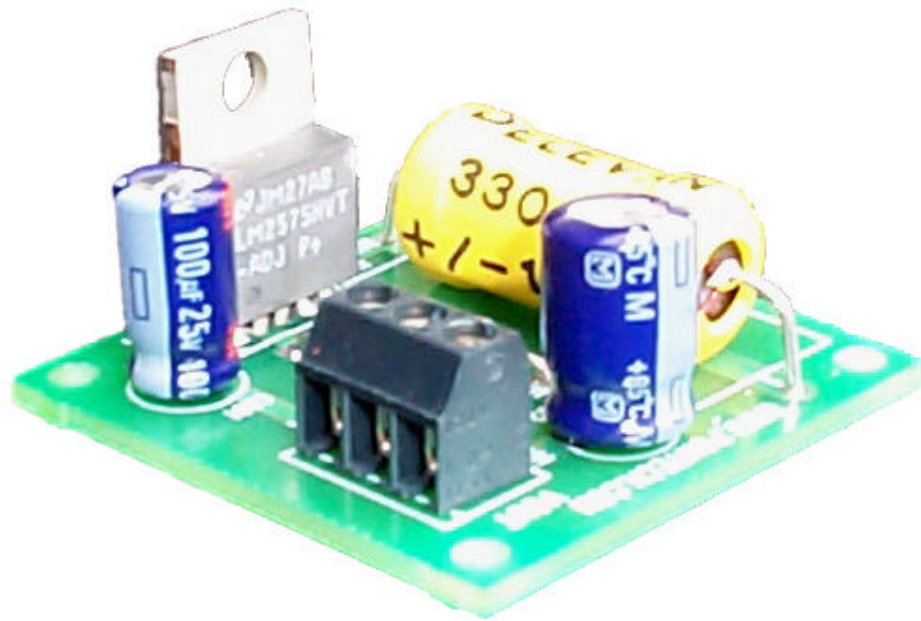

DC-DC Buck Converter

Rev. 2003-06Jun-24 12:52

www.pontech.com

© Copyright 2003 ProLinear/PONTECH, Inc.

BUK100 – Users Manual

General Description

The BUK100 is a high efficiency dc-to-dc buck converter. That is, the BUK100 will take an unregulated dc input voltage and will give a desired regulated dc output. An application of the BUK100 might be:

You are using a motor controller (perhaps the STP100). You wish to power the motor with 24VDC; however, the controller requires 8VDC for logic power. Rather than having two power supplies, or lowering the voltage of one supply through linear regulators; you can power the controller through the BUK100 and still power the motors with 24VDC using one supply.

The use of the BUK100 in such an application has great advantages. For one, the use of a single power supply is cost and space efficient. Also, the BUK100's method of using PWM (pulse width modulation) to achieve a desired effective VDC is much more energy efficient than the use of linear regulator. Therefore, the BUK100 is cost and space efficient as well as being energy efficient.

Connections

The BUK100 has three terminal connections: (VIN) on terminal 1, Ground (GND) on terminal 2, and (VOUT) on terminal 3. The input on terminal 1 (VIN) is where the higher dc voltage is applied. The output on terminal 3 (VOUT) is where the lower regulated voltage is taken from. The ground (not labeled), which is terminal 2, is shared by both the input as well as the output.

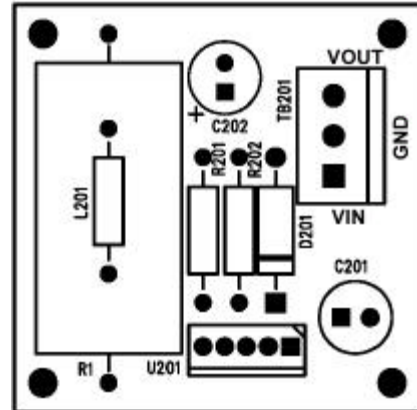

Using the BUK100

The buck converter is very easy to use. You simply connect the output (VOUT) to your to the device you wish powered (the load), connect the higher input DC voltage to the input (VIN), and. The ground leads for both VIN and VOUT are shared on center GND terminal.

NOTE: The order of connections may be important to prevent damage to the load, make sure to connect the load to the output before powering the board. If there is no load, the output voltage will drift slowly up to the input voltage, it is suggested not to run the BUK100 with out a load.

BUK100 - Specifications

Specifications

	Min	Typ	Max	Units
Input Voltage*	7		40	VDC
Output Current	0.2		1000	mA
Output Voltage**	1.23		37	VDC
BUK001-5		5		VDC
BUK001-7		7		VDC
BUK001-8		8		VDC

*Input voltage must be greater than output voltage by at least 3V

**Output voltage depends on model number

Test Data

The following represents test data taken with a typical unit. The BUK100 ships with a 330uF capacitor, the following table shows that ripple can be minimized with greater capacitance on the output.

Vout	Load (Ohms)	Ouput Cap = 330uF				Ouput Cap = 800uF			
		Vin = 10V		Vin = 20V		Vin = 10V		Vin = 20V	
		Vout (V)	Vripple (mV)	Vout (V)	Vripple (mV)	Vout (V)	Vripple (mV)	Vout (V)	Vripple (mV)
5V	5	5.00	35	5.00	60	5.00	20	5.00	30
5V	10	5.00	30	5.00	50	5.00	20	5.00	30
5V	20	5.00	40	5.00	60	5.00	30	5.00	35
5V	40	4.95	45	4.95	55	4.95	20	4.95	30
5V	50	4.95	35	5.00	55	4.95	20	5.00	30
5V	60	5.00	35	5.00	50	5.00	20	5.00	25
7V	10	7.00	30	7.00	55	7.00	20	7.00	40
7V	20	6.95	25	6.95	55	6.95	15	6.95	30
7V	40	7.00	30	7.00	65	7.00	20	7.00	40
7V	50	6.95	35	6.95	60	6.95	15	6.95	40
7V	60	6.95	35	6.95	55	6.95	15	6.95	30
8V	10	8.00	20	8.00	65	8.00	10	8.00	35
8V	20	8.00	20	8.00	65	8.00	15	8.00	35
8V	40	8.00	25	8.10	65	8.00	20	8.10	40
8V	50	8.00	15	8.10	60	8.00	10	8.10	35
8V	60	8.10	20	8.10	60	8.10	20	8.10	30

BUK100 – Warranty and Copyrights

Warranty

ProLinear/PONTECH, Inc. warrants its products against defects in materials and workmanship for a period of 90 days.

If you discover a defect, ProLinear/PONTECH, Inc. will, at its option, repair, replace or refund the purchase price. To exercise warranty, please contact ProLinear/PONTECH, Inc. at either our toll free number or by way of e-mail using the address warranty@pontech.com. You will also need to return the product with a description of the problem and a copy of your invoice (if you do not have a copy of your invoice, please include your name and telephone number).

Copyright and Trademarks

Copyright © 2003 by ProLinear/PONTECH, Inc. All rights reserved.

Disclaimer of Liability

ProLinear/PONTECH, Inc. is not responsible for special, incidental, or consequential damages resulting from any breach of warranty, or under any legal theory, including lost profits, downtime, goodwill, damage to or replacement of property, and any costs of recovering, reprogramming, or reproduction and data stored in or used with ProLinear/PONTECH, Inc. products.